

PLE

- PLE applications 67
- PLE dimensions 68
- PLE types 69
- PLE sizes 71
- PLE parts 72
- PLE assembly 73
- PLE part numbers 76

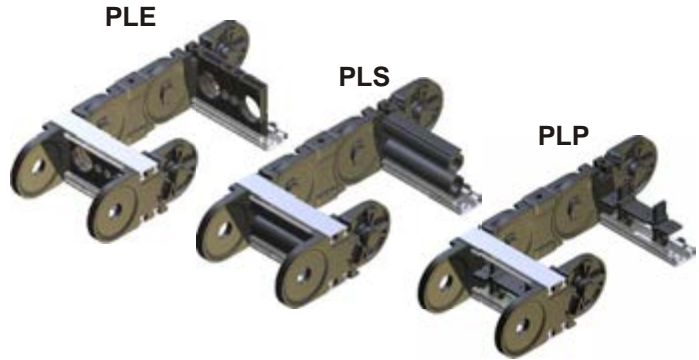

closed + open



The PLE with aluminum stays is available as **PLE** with plastic inserts or plastic slot profile, as **PLS** with foam slot profile or as **PLP** with plastic divider PZ.

- positive stay locking
- both inside and outside radius can be opened
- simple to shorten or lengthen
- stepless stay length up to 1000 mm

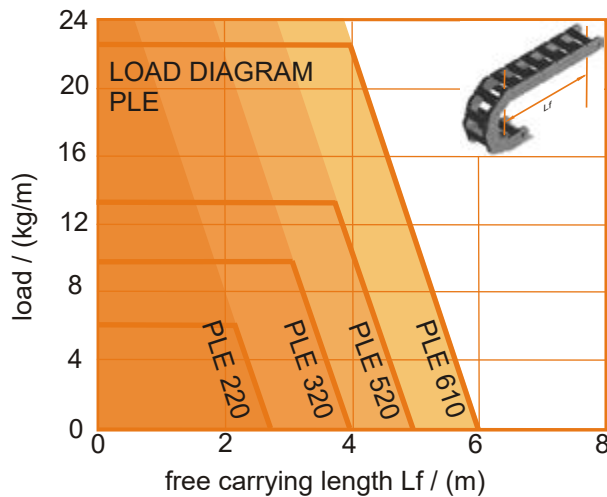

All HELU plastic energy chains are equipped with the **integrated connector**. Additional components for mounting the energy chain are not required.

Travel

The maximum travel is determined by the arrangement and the additional weight (line weight). At normal arrangement the maximum travel is twice the free carrying length. Support rollers or similar constructive steps can increase this value.

In gliding arrangements travel distances up to 100 meters are possible.

Longer travel distances need further constructive steps, like SYSTEM MARATHON, which exceeds the travel distance nearly without limits.

Travel speed

There are no limits for the travel speed in general. But in gliding applications specific influences have to be taken into account.

Acceleration

In principle there are no restrictions for the acceleration. Limits can only be achieved at high tension forces caused by high additional weights.

Temperature

The operating temperature is inbetween -20 °C and 100 °C.

Special versions

- | | |
|----------|------------------------|
| ALLROUND | ... all movements |
| ATEX | ... EX-protection |
| ESD | ... antistatic |
| V-0 | ... self extinguishing |

APPLICATION AREAS

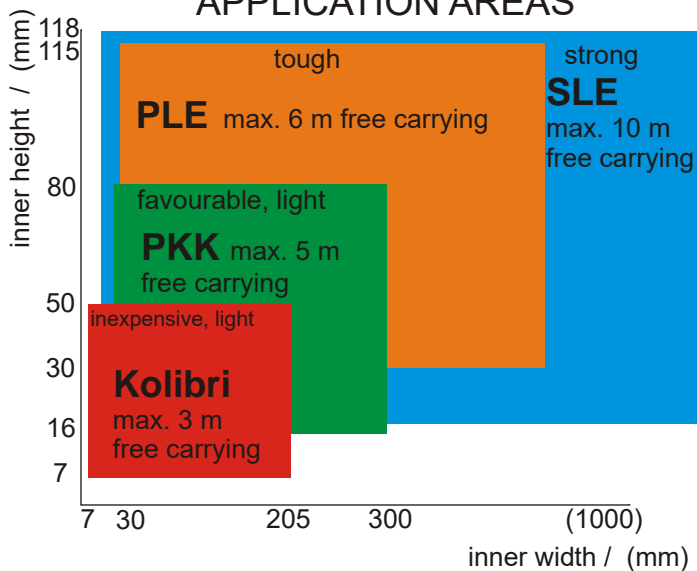

PLE APPLICATIONS

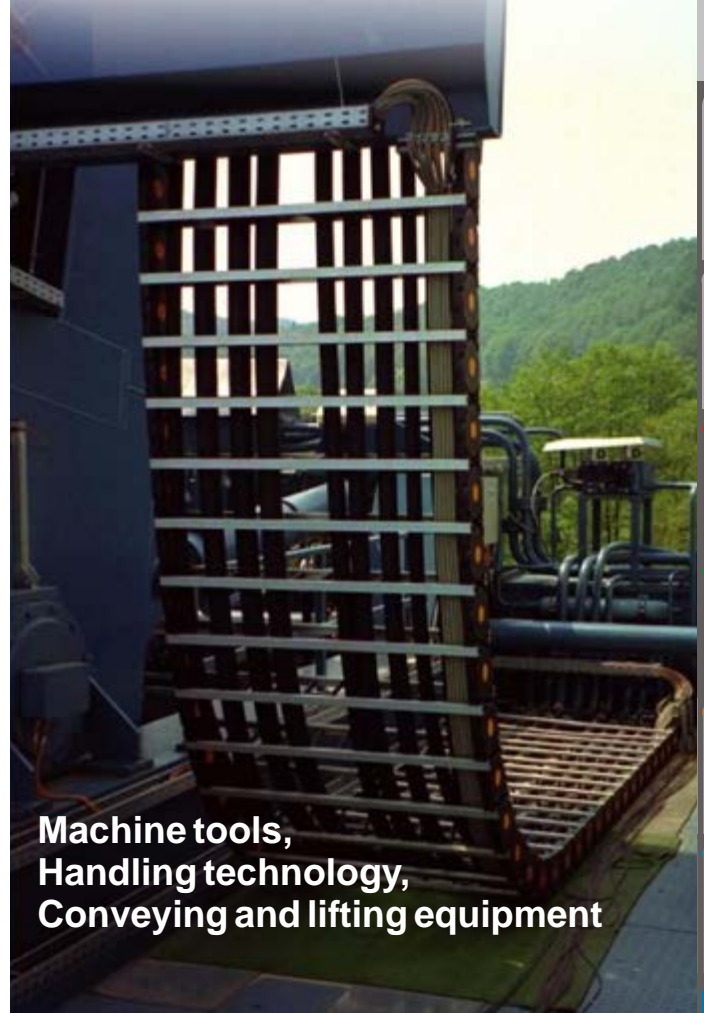

PLE DIMENSIONS

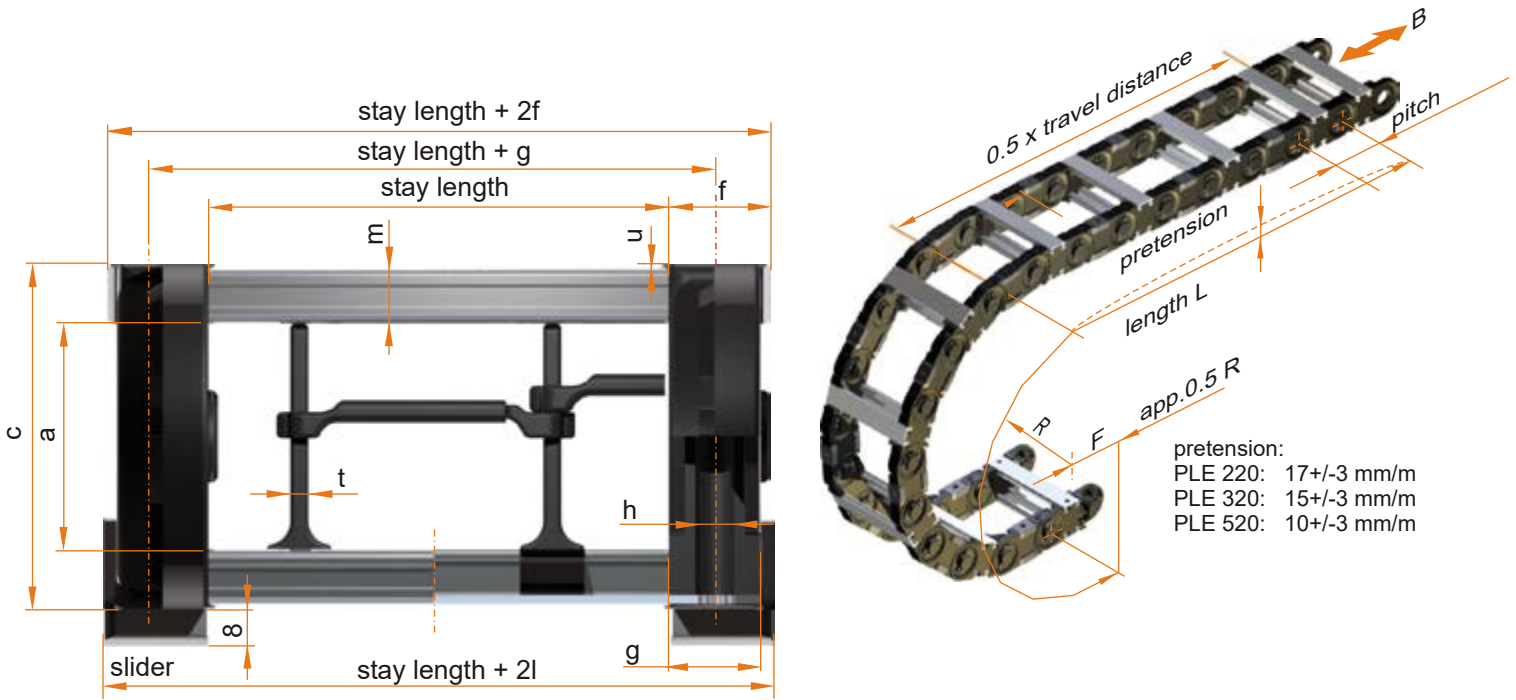

pretension:
 PLE 220: 17+/-3 mm/m
 PLE 320: 15+/-3 mm/m
 PLE 520: 10+/-3 mm/m

The usable interior width is stay length - 2 mm

PLE	bending radius R [mm]	pitch	a	c	f	g	h	l ¹⁾	m	t	u	weight [kg/m] ³⁾
220, 221	75 100 150 200 300	75	31	50	18	16	Ø6	-	9	4	1	1.9
320, 321, 325, 328 ²⁾	150 200 250 300 400	100	49	75	22	20	Ø8	23	12	4	1	3.4 (4.4)
520, 521, 525, 528 ²⁾	200 250 300 400 500	125	68	100	26	24	Ø8	27	15	4	1	4.8 (5.9)
541, 548 ²⁾	200 250 300 400 500	125	80	100	26	24	Ø8	27	9	4	1	4.60

1) stay length + 2l is the outside width, including sliders 2) PLE 328 from R200, PLE 528, 548 from R250
 3) weight with stay length 100, values in brackets for closed version

PLE	minimum stay length [mm]	maximum stay length [mm]	PLE inserts Ø [mm]														
220, 221	50	800	10	15	20	25	30										
320, 321, 325, 328	60	900	10	15	20	25	30	35	40	45	50						
520, 521, 525, 528	70	1000	10	15	20	25	30	35	40	45	50	55	60	65	70		
541, 548	70	900															

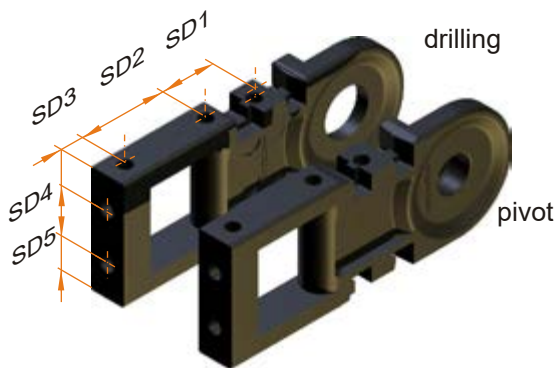

The stay lengths are offered in steps of 1 mm.

PLE SD- connector	SD1	SD2	SD3	SD4	SD5
220, 221, 225	22,5	37,5	8,5	22	7,5
320, 321, 325, 328	35	45	8,5	45	15
520, 521, 525, 528	35	45	8,5	66	17

order example: travel distance 3 m, bending radius 200 mm, cable: 1x15 mm, 8x8 mm, 3x12 mm, 2x22 mm, chain arrangement is hanging

PLE 320 / 200	x	2300	/ 200	/ SD 32, SD 32	/ h	/ 5 PZ, 1 Pt55
type / radius	x	length	/ stay length	/ connectors	/ arrangement	/ stay distribution

PLE TYPES

PLE energy chains are distinguished from standard plastic chains by their extreme stability and the rigid, continuously adjustable aluminum profile. Stay lengths up to 1000 mm can be accommodated.

The allocation of the interior offers variable opportunities and guarantees optimum line protection even at high acceleration and travel speed.

The **PLE** (PLE with plastic inserts or plastic insert-profile) ensures a perfect guide at high speeds. Errors during installation of the cables are nearly impossible, with this variation, the hole design of the stays meet exactly the requirements of the lines. Plastic inserts are available in 5 mm steps. The plastic insert-profile can be ordered according to drawing.

In case of limited installation space, the **PLS** (PLE with foam insert-profile) are used. Again, the optimal guiding of the lines at high speeds and acceleration is ensured. All lines are in the neutral axis (middle of chain height).

For space reasons the **PLP** (PLE with plastic dividers) may be chosen. This inexpensive design allows secure guiding of large amounts of cable. The highly variable stay distribution opportunities through the small steps (3mm) in height and the infinitely adjustable plastic telescopic dividers (PT) allow maximum space for all needs, even when changes in cable diameters are required.

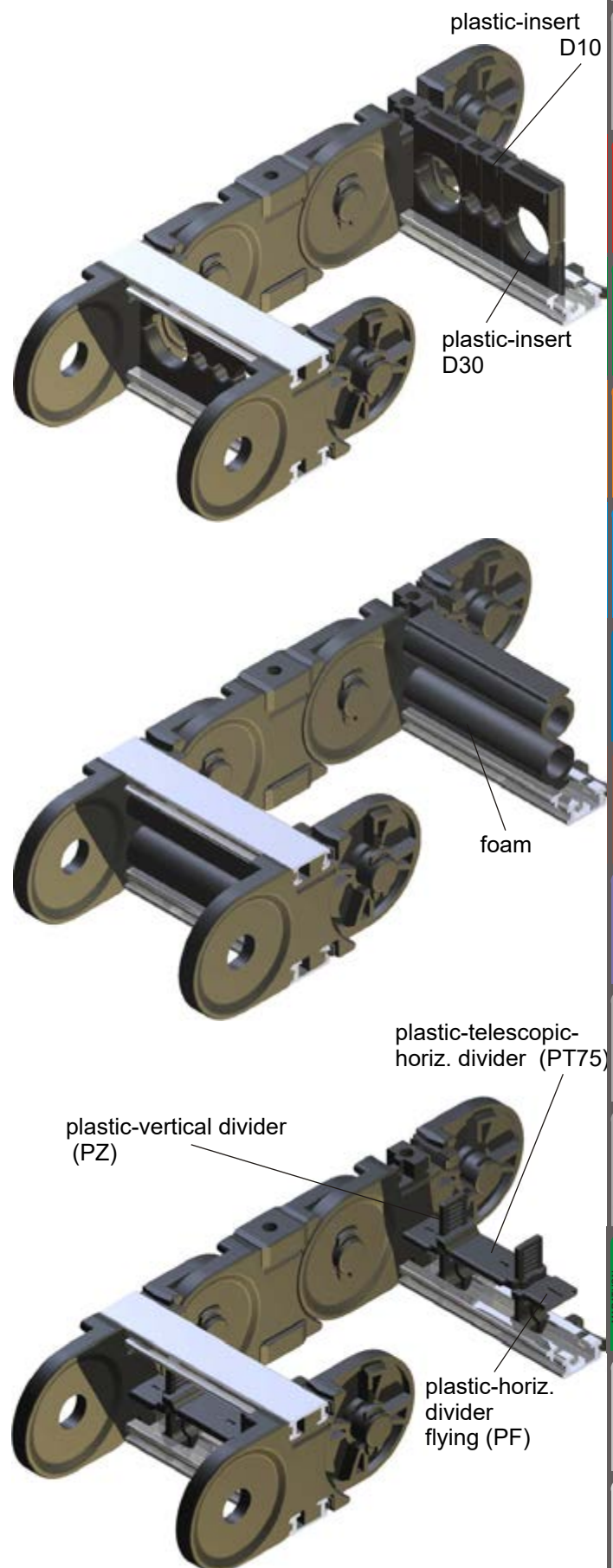

PLE TYPES

PLE 220, 320, 520

The standard type is build with stays in every second chain link. The **integrated connector** makes every link in the chain when needed to a connector (not 620) and therefore the separate ordering and storage of end connector brackets is not necessary.

order example:

PLE 220	/ 100	x 3525	/ 100
type	radius	length	stay length

PLE 221, 321, 521, 541

These designs are made with stays in each link. This increases the lateral stability and improves the guiding particularly of smaller diameter lines.

order example:

PLE 221	/ 100	x 3525	/ 100
type	radius	length	stay length

PLE 325, 525

The closed types with aluminum covers may also replace the standard version stay. The covers can be opened in the inner or outer radius.

order example:

PLE 325	/ 300	x 3500	/ 100
type	radius	length	stay length

PLE 328, 528, 548

These types are suitable for long travel, the upper strand slides on the lower strand. For increased stability these energy chains are also build with stays in each link. The energy chains are fitted with sliders in the inner radius, which have a very low coefficient of friction ($\mu = 0.2$ to 0.25). After reaching the wear limit, the slider can be renewed and the energy chain will continue. Subsequent slider assembly is also possible. Then, the stays must be provided with drilled location holes.

order example:

PLE 328	/ 200	x 3500	/ 100
type	radius	length	stay length

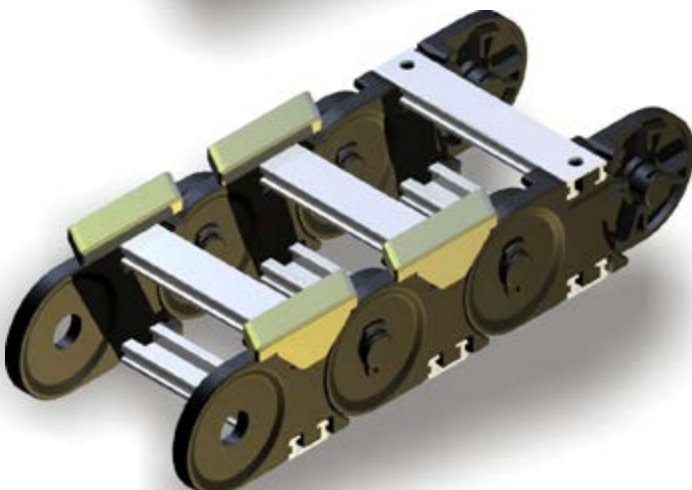
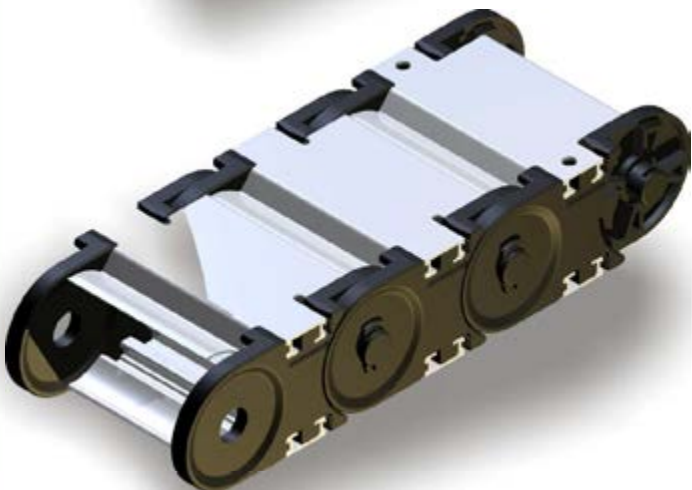
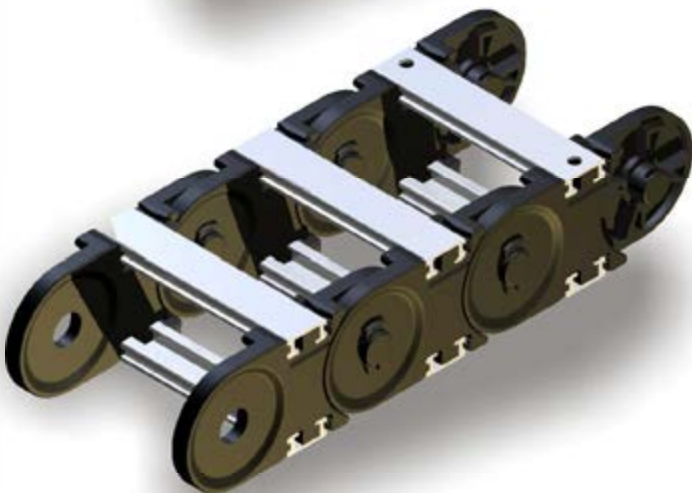
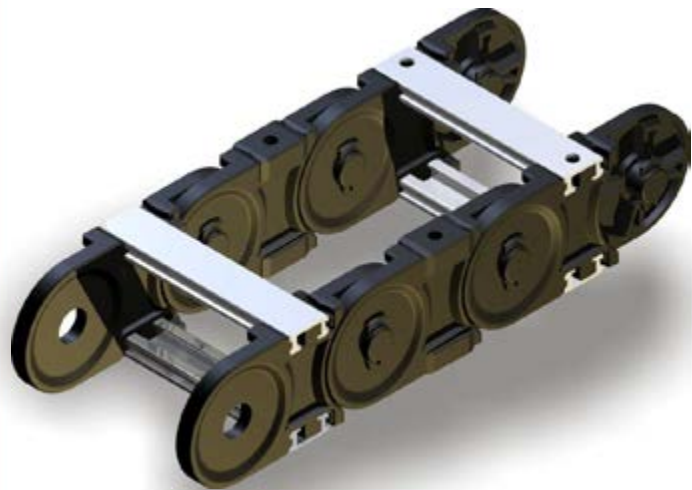

PLE SIZES

PLE 220

standard type

height: 50 width: 86 ... 836
inner height: 31 inner width: 50 ... 800



PLE 320

standard type

height: 75 width: 104 ... 944
inner height: 49 inner width: 60 ... 900



PLE 520

standard type

height: 100 width: 122 ... 1052
inner height: 68 inner width: 70 ... 1000

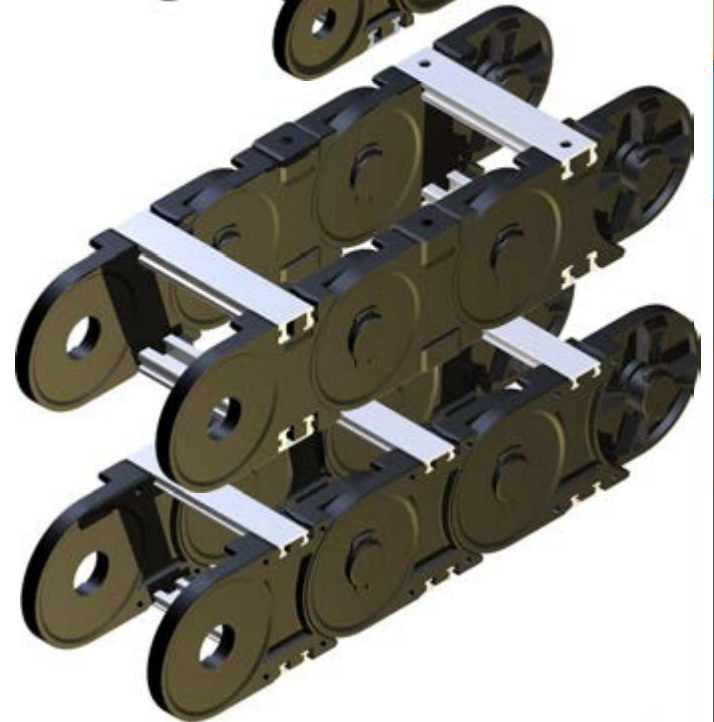

PLE 541

stay in each link

height: 100 width: 122 ... 1052
inner height: 80 inner width: 70 ... 1000

PLE PARTS

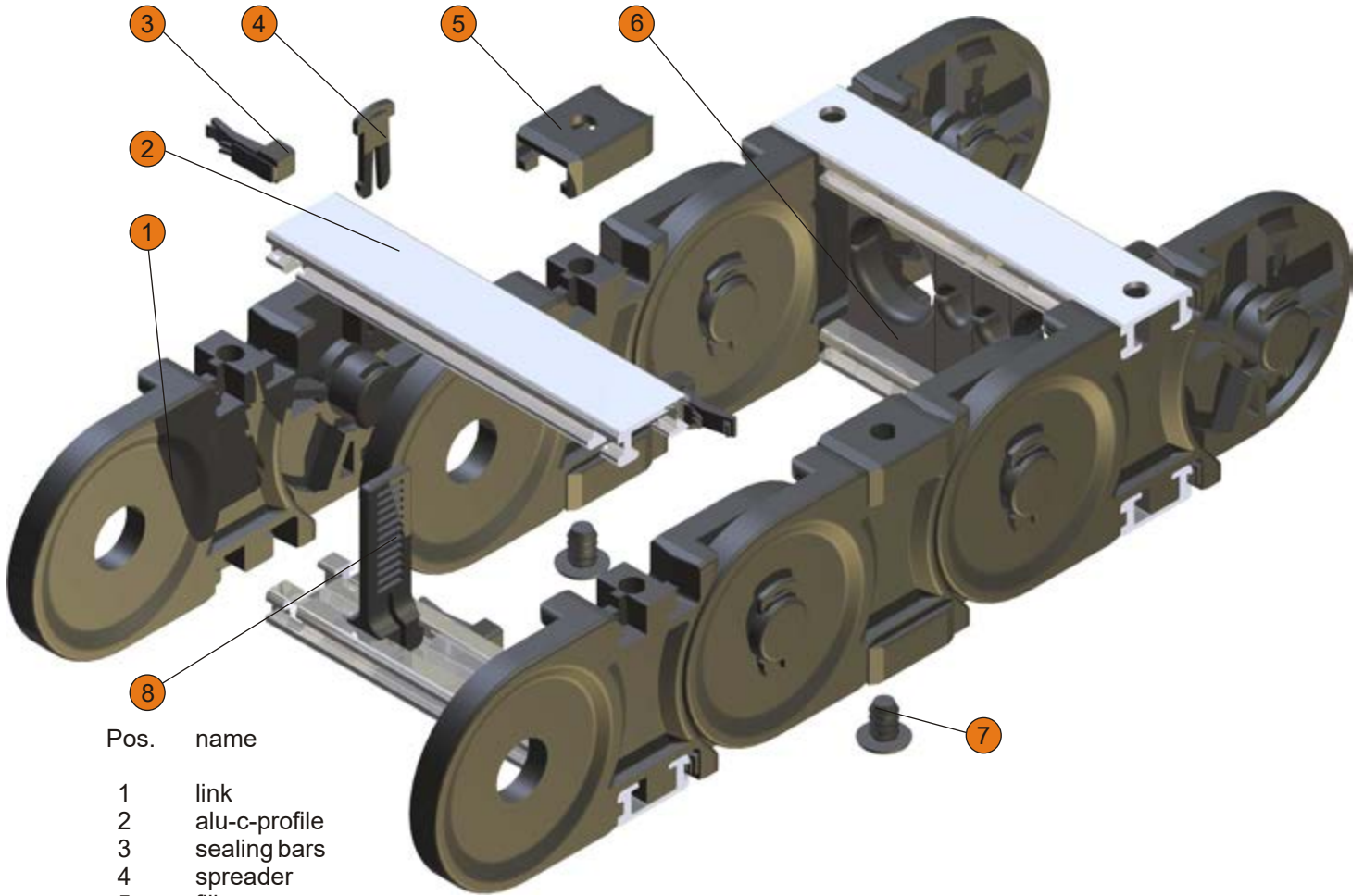

Pos.	name
1	link
2	alu-c-profile
3	sealing bars
4	spreader
5	filler
6	insert
7	damping element
8	plastic vertical divider (PZ)
9	inner cover
10	outer cover

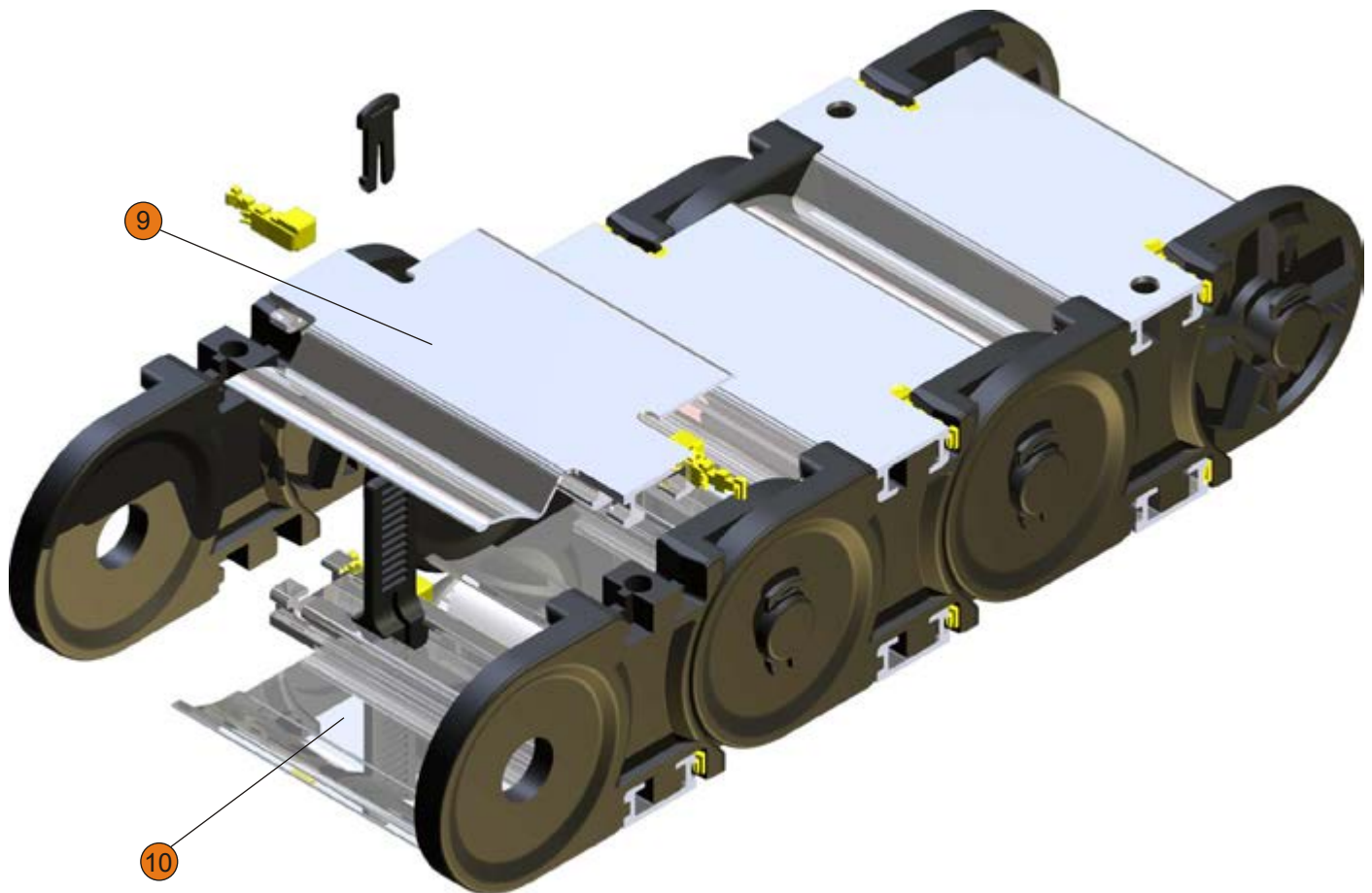

PLE ASSEMBLY

Lengthening or shortening, link bands

To shorten the spreaders are disengaged (1), taken from (2,3) and the corresponding piece of chain removed (4). Lengthening is done by adding links and inter-lock with the spreaders.

Alternatively, first part of strands assembled or dismantled. Then a stay assembly or disassembly is required.

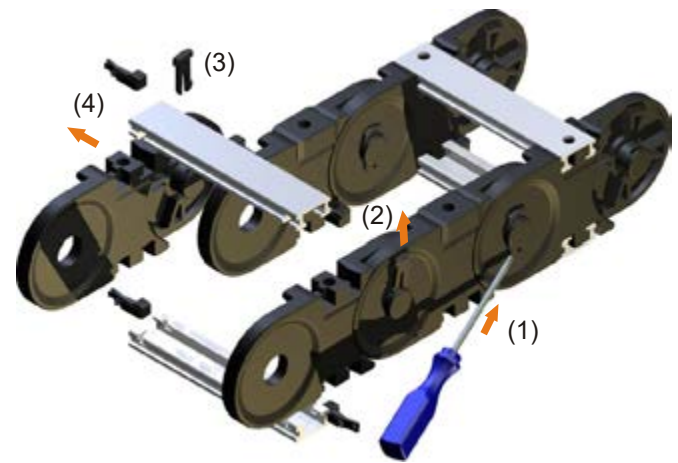

Stay assembly

Stays are installed (1) and locked by horizontal shifting into place (2). Then pushing the sealing bars outside until they lock the link.

Stay disassembly

Push sealing bar to the inside (4), unlock stay (5) and remove them (6).

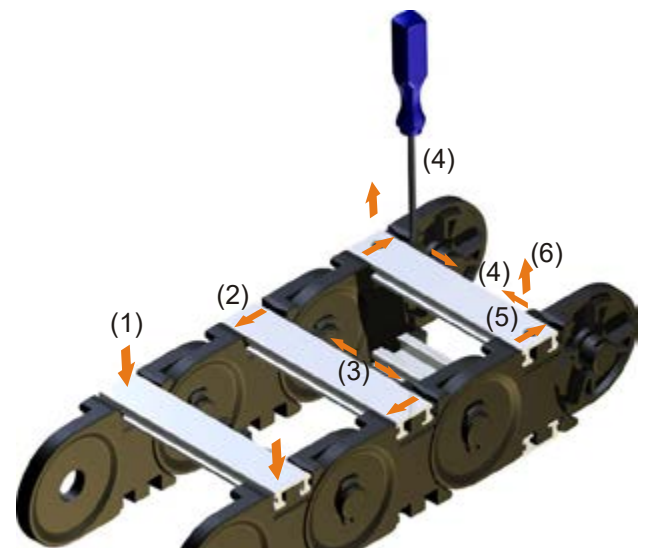

Filler

The fillers are mounted in the recess and (possibly with a light plastic hammer) pushed until locked (1).

The dismantling of the fillers is done with a screwdriver. The screwdriver blade ought to be small enough to start behind the filler. Then unhinge the filler (2).

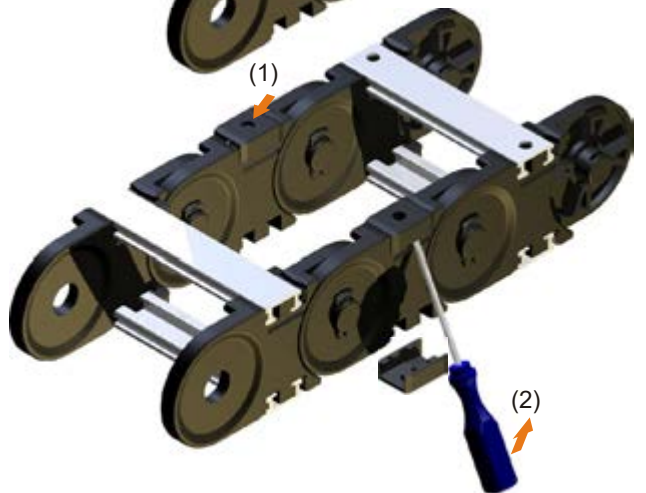

Covers

The assembly of the covers is the same as the assembly and disassembly of the stays. The sealing bar is positioned in the designated position with a screwdriver.

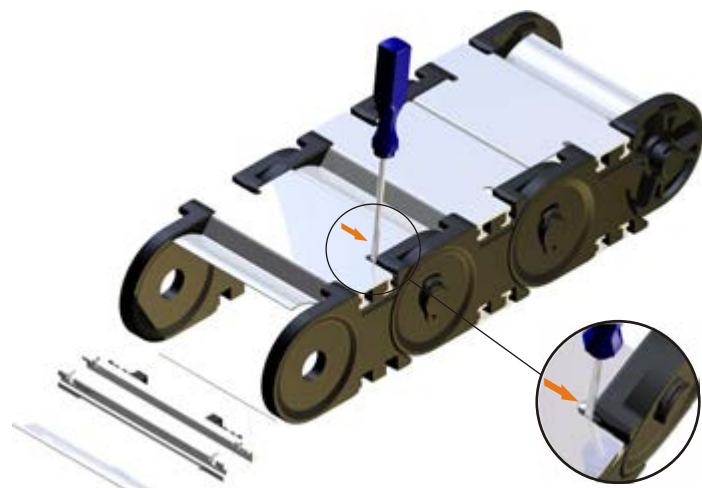

PLE ASSEMBLY

Plastic inserts

The inserts are assembled according to the required lateral position (1) and inserted into the stay (2).

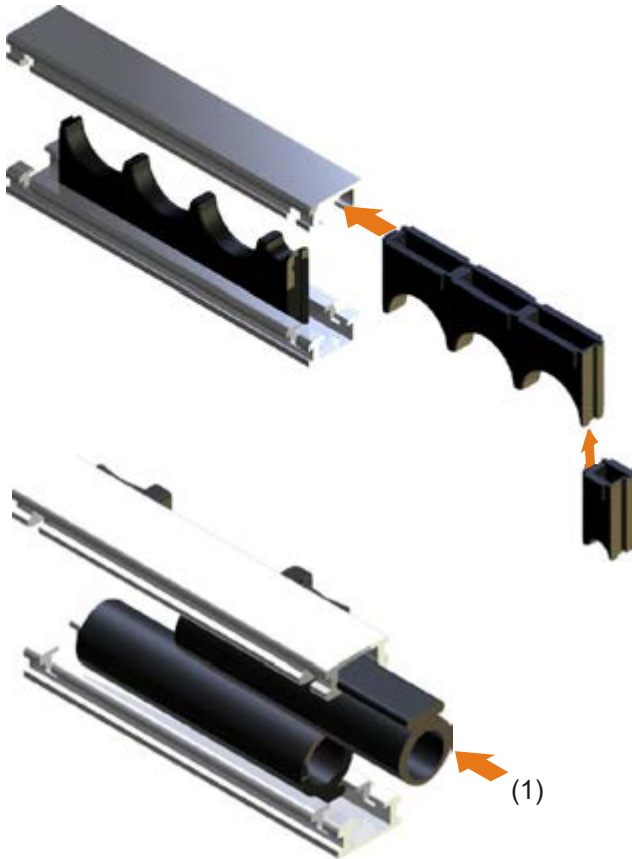

Foam

The foam insert is pushed laterally into the aluminum-profile (1), before they are assembled to the chain links.

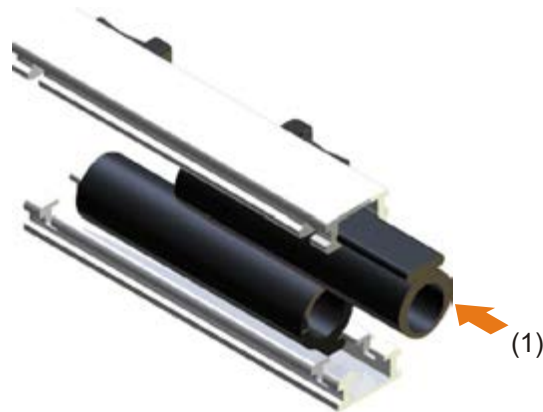

Plastic divider PZ

The plastic dividers are hooked into the desired position with the long side of the foot in the aluminum bar and engaged with slight pressure (1).

Corrections of the position by lateral displacement are possible. The dismantling of the PZ is done by pulling in the opposite direction or sideways push out from the stay.

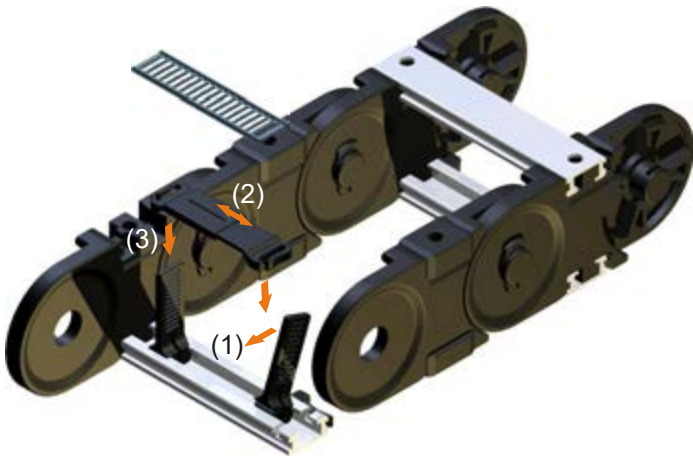

Telescopic horizontal divider

The telescopic horizontal divider can be adjusted in length (2), vertically fitted on the PZ (3) and engaged in the designated height.

The dismantling is carried out with a screwdriver by unlocking and removal.

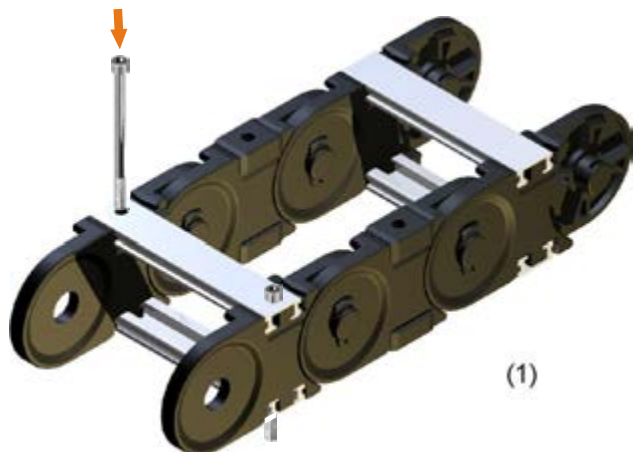

Mounting the energy chain

All HELU plastic energy chains are equipped with **integrated connectors**. They allow the mounting of the energy chain with any link.

In gliding energy chain applications or for a smooth optical effect, the mounting holes in the fixed connector can be countersunk.

PLE ASSEMBLY

Face mounting

The energy chain PLE can be optionally fitted with flange connectors. The flange connectors allow various mounting opportunities, mounted like chain links and secured with a stay.

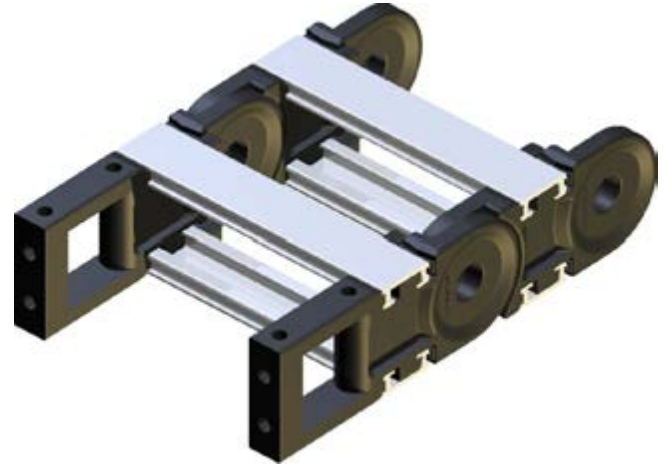

Sliders

To avoid damage the slider must be conditioned (overnight storage in water at room temperature or 2 h at 80 ° C).

The slider is positioned at the inner radius of the energy chain, with the pin in the bore of the stay (1) and pushed until the snap hook locks (2).

To dismantle unhinge the snap hook (3) and remove the slider to the top (4).

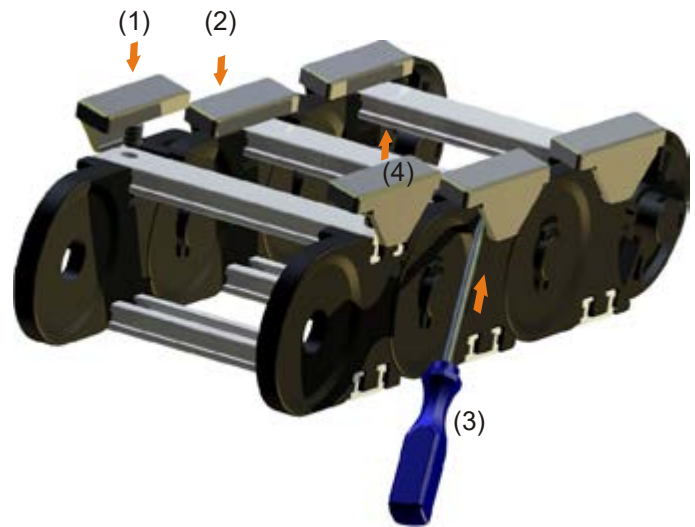

The implementation of an energy chain with sliders has to be done smoothly. In addition, the glide bars (1) should be fitted with contour at the end of the energy chain and counter sinking the connector screws (2). The distance between the glide bar to the first slider should be less than the slider length (3).

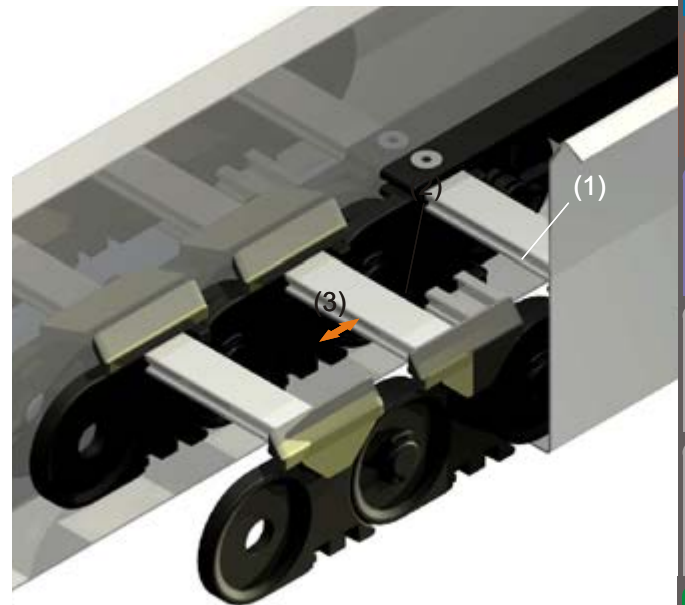

Maintenance of the energy chain

PLE energy chains are maintenance free. Like every mechanical system this will depend on the ambient conditions so wear will occur which must be observed.

In case of the energy chain has to be replaced.

For long travels or in a circular motion, the energy chains are often equipped with sliding elements. These allow sliding of the upper part of the chain on a suitable surface (eg, slider-slider, slider-steel, glide bar).

The sliders wear depends on the application. The slider surfaces should be checked at regular intervals. With a thickness of 1-2 mm sliders have to be replaced.

PLE PART NUMBERS

PLE parts 72

special material parts like UI94 V-0, EX or other have to be named in the order



1

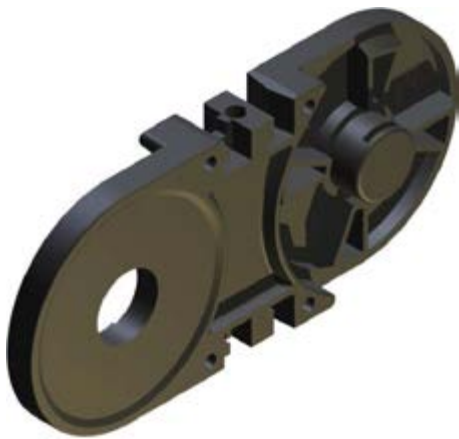

PLE	link						
	R	75	100	150	200	300	
220	m.V.	0346	1190	1219	1191	1192	
	o.V.	1193	1194	1218	1195	1196	
221	m.V.	0346	1190	1219	1191	1192	
	o.V.	1193	1194	1218	1195	1196	
	R	150	200	250	300	400	
320	m.V.	0351	1197	1198	1199	1200	
	o.V.	1201	1202	1203	1204	1205	
321	m.V.	0351	1197	1198	1199	1200	
	o.V.	1201	1202	1203	1204	1205	
325	m.V.	0351	1197	1198	1199	1200	
	o.V.	1201	1202	1203	1204	1205	
328	m.V.	-	1197	1198	1199	1200	
	o.V.	-	1202	1203	1204	1205	
	R	200	250	300	400	500	
520	m.V.	0944	1206	1207	1208	1209	
	o.V.	1211	1212	1213	1214	1215	
521	m.V.	0944	1206	1207	1208	1209	
	o.V.	1211	1212	1213	1214	1215	
525	m.V.	0944	1206	1207	1208	1209	
	o.V.	1211	1212	1213	1214	1215	
528	m.V.	-	1206	1207	1208	1209	
	o.V.	-	1212	1213	1214	1215	
	R	200	250	300	400	500	
541	m.V.	1611	1607	1608	1609	1610	
	o.V.	-	-	-	-	-	
548	m.V.	1611	1607	1608	1609	1610	
	o.V.	-	-	-	-	-	
R	219	250	315	410	500	700	315/1600

PLE PART NUMBERS

4



5



7



2



3



10

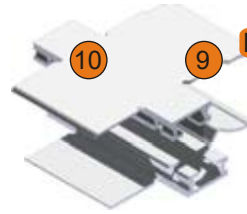

9



PLE parts

72

PLE

SR

PS

FK

C-profile

SRR/SRR5

ASA

ASI

foam

220	0348	0345	1269	0976	0344	-	-	-
221	0348	-	1269	0976	0344	-	-	-
320	0353	0350	1317	0977	0349	-	-	2365
321	0353	-	1317	0977	0349	-	-	2365
325	0353	-	1317	-	1668 1669	1640	1638	2365
328	0353	-	1317	0977	0349	-	-	2365
520	0358	0943	1317	0978	0942	-	-	2365
521	0358	-	1317	0978	0942	-	-	2365
525	0358	-	1317	-	1656 1657	1641	1639	2365
528	0358	-	1317	0978	0942	-	-	2365
541	0358	-	1317	0976	1676	-	-	-
548	0358	-	1317	0976	1676	-	-	-

PLE PART NUMBERS

PLE parts 72

8



PLE	PZ	PTF	PT 55	PT 75	LL 25	LL 50	LS	GL	ZL	ZLA8	ZLS10	ZHS10	SDA Drilling Pin	
-----	----	-----	-------	-------	-------	-------	----	----	----	------	-------	-------	---------------------	--

220	0778	1519	1927	0879	0880	1663	1664	1665	-	1273	1159	1160	1407	1439	1761
221	0778	1519	1927	0879	0880	1663	1664	1665	-	1273	1159	1160	1407	1439	1761



320	0163	1678	1927	0879	0880	1663	1664	1665	-	1273	1159	1160	1407	1773	1774
321	0163	1678	1927	0879	0880	1663	1664	1665	-	1273	1159	1160	1407	1773	1774
325	0163	1678	1927	0879	0880	1663	1664	1665	1450	1273	1159	1160	1407	1773	1774
328	0163	1678	1927	0879	0880	1663	1664	1665	1450	1273	1159	1160	1407	1773	1774



520	0719	1680	1927	0879	0880	1663	1664	1665	-		1159	1160	1407	1775	1776
521	0719	1680	1927	0879	0880	1663	1664	1665	-		1159	1160	1407	1775	1776
525	0719	1680	1927	0879	0880	1663	1664	1665	1449		1159	1160	1407	1775	1776
528	0719	1680	1927	0879	0880	1663	1664	1665	1449		1159	1160	1407	1775	1776

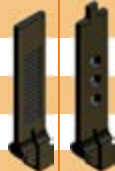

541	1613		1927	0879	0880	1663	1664	1665	-	1675	1159	1160	1407		
-----	------	--	------	------	------	------	------	------	---	------	------	------	------	--	--

548	1613		1927	0879	0880	1663	1664	1665	1449	1675	1159	1160	1407		
-----	------	--	------	------	------	------	------	------	------	------	------	------	------	--	--

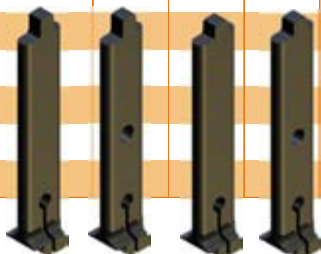

PLE PART NUMBERS

inserts

special material parts like UI94 V-0, EX or other have to be named in the order

6

PLE parts

72

diameter in mm



PLE

10 15 20 25 30 35 40 45 50 55 60 65 70

PLE	10	15	20	25	30	35	40	45	50	55	60	65	70
220	0649	0650	0651	0652	0653	-	-	-	-	-	-	-	-
221	0649	0650	0651	0652	0653	-	-	-	-	-	-	-	-
320	0654	0665	0656	0657	0658	0659	0660	0661	0662	-	-	-	-
321	0654	0665	0656	0657	0658	0659	0660	0661	0662	-	-	-	-
325	0654	0665	0656	0657	0658	0659	0660	0661	0662	-	-	-	-
328	0654	0665	0656	0657	0658	0659	0660	0661	0662	-	-	-	-
520	1628	0663	0664	0665	0666	0667	0668	0669	0670	0671	0672	0714	0715
521	1628	0663	0664	0665	0666	0667	0668	0669	0670	0671	0672	0714	0715
525	1628	0663	0664	0665	0666	0667	0668	0669	0670	0671	0672	0714	0715
528	1628	0663	0664	0665	0666	0667	0668	0669	0670	0671	0672	0714	0715

Content
 Design guidelines
 Order infos
 Kolibri
 PKK
 PLE P/LP PLA
 SLE SLP SLA
 GKA
 SFK
 PFR
 Troughs
 Systems
 Materials
 Informations